

Ferrules – Metric / Imperial

Ferrules are produced by turning from 316L stainless steel bar stock. The surface finish is equal to or more often better than those quoted in the relevant standards. Ferrules are also available with enhanced surface finish to 0.38 $\mu\text{m Ra}$, this being achieved by electro polishing. Material certification is supplied as standard and all ferrules are part marked with the material grade, mill heat number and the fittings size and name. Ferrules can also be supplied as specials in a variety of non-standard materials such as special stainless steels, titanium, hastalloy etc.



Technical information

Sizes	see table
Connections	Tri-Clamp
Material	1.4404 (316L)
Finishes	0.8 Ra(μm) / 32 Ra(μin)
Certificates	3.1 - Solid Bar

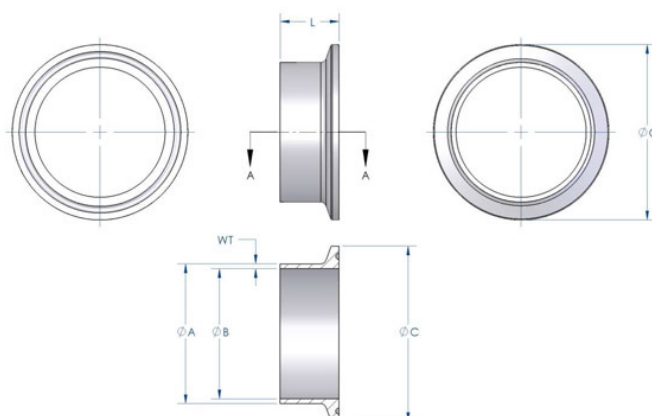

Size Metric (Imperial)	OD ØA	ID ØB	Flange ØC	Wall WT	Length L	Mass (kg)
25.4 (1.0")	25.4	22.1	50.5	1.65	21.5	0.07
38.1 (1.5")	38.1	34.8	50.5	1.65	21.5	0.06
51.0 (2.0")	50.8	47.5	64.0	1.65	21.5	0.08
63.5 (2.5")	63.5	60.2	77.5	1.65	21.5	0.10
76.1 (3.0")	76.2	72.9	91.0	1.65	21.5	0.13
101.6 (4.0")	101.6	97.4	119.0	2.10	21.5	0.21